



A DIVISION OF HY-TECH MACHINE, INC.

TYPE "D" SMALL PIPE DATA SHEET

PIPE I.D. SIZES

0.957" – 2.469"

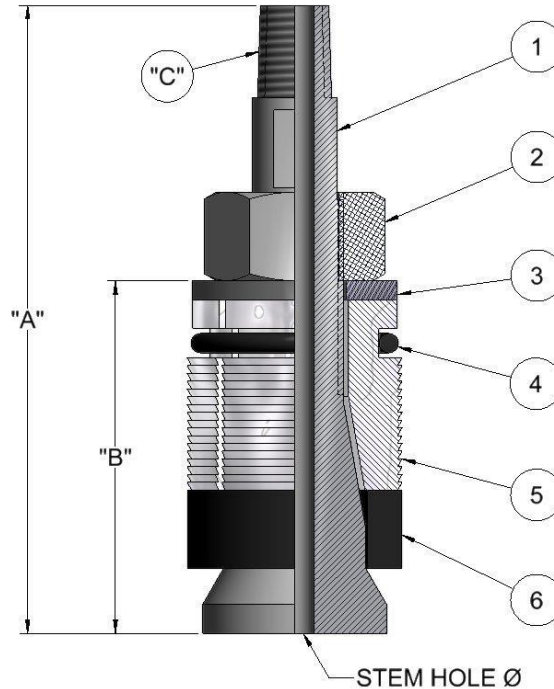

PARTS LIST

- | | | |
|------------|------------------|-------------|
| 1. MANDREL | 3. WASHER | 5. GRIPS |
| 2. NUT | 4. O-RING (GRIP) | 6. SEAL CUP |

| STOPPER SIZE | THAXTON PART # | NOMINAL PIPE SIZE | "A" DIM. | "B" DIM. | "C" DIM. (MALE) N.P.T. | STEM HOLE Ø | NUT THREAD SIZE | SAFETY GAG PART # |
|--------------|----------------|-------------------|----------|----------|------------------------|-------------|-----------------|-------------------|
| 0.957 | D-0.957-0 | 1" SCH. 80 | 4-1/8" | 2.54" | 1/4-18 | 1/4" | 5/8-18 | SG-1 |
| 1.049 | D-1.049-0 | 1" SCH. 40 | 3-7/8" | 2.09" | 1/4-18 | 1/4" | 5/8-18 | SG-1 |
| 1.278 | D-1.278-0 | 1-1/4" SCH. 80 | 4-1/32" | 2.26" | 1/4-18 | 1/4" | 5/8-18 | SG-1.25 |
| 1.380 | D-1.380-0 | 1-1/4" SCH. 40 | 4-1/32" | 2.26" | 1/4-18 | 1/4" | 5/8-18 | SG-1.25 |
| 1.500 | D-1.500-0 | 1-1/2" SCH. 80 | 4-1/2" | 2.38" | 3/8-18 | 3/8" | 7/8-14 | SG-1.5 |
| 1.610 | D-1.610-0 | 1-1/2" SCH. 40 | 4-1/2" | 2.38" | 3/8-18 | 3/8" | 7/8-14 | SG-1.5 |
| 1.939 | D-1.939-0 | 2" SCH. 80 | 4-15/16" | 2.54" | 1/2-14 | 3/8" | 1"-14 | SG-2 |
| 2.067 | D-2.067-0 | 2" SCH. 40 | 4-15/16" | 2.54" | 1/2-14 | 3/8" | 1"-14 | SG-2 |
| 2.323 | D-2.323-0 | 2-1/2" SCH. 80 | 5-1/8" | 2.80" | 3/4-14 | 3/8" | 1 1/4-12 | SG-2.5 |
| 2.469 | D-2.469-0 | 2-1/2" SCH. 40 | 5-1/8" | 2.80" | 3/4-14 | 3/8" | 1 1/4-12 | SG-2.5 |

THAXTON PIPE STOPPERS ARE FACTORY TESTED UP TO 3,000 PSI, DEPENDING ON SIZE

SPECIAL SIZES AND HIGHER PRESSURES CAN BE SUPPLIED PER CUSTOMER REQUIREMENTS