

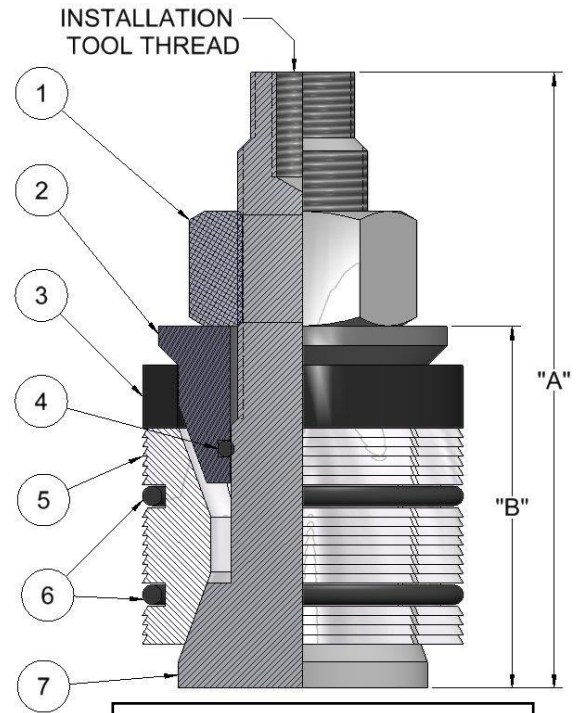

A DIVISION OF HY-TECH MACHINE, INC.

REVERSE PRESSURE TYPE "D" DATA SHEET

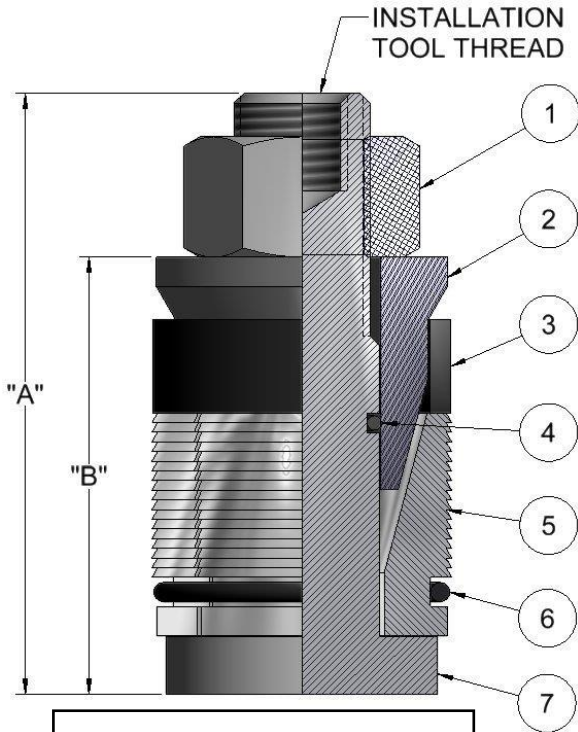

- PARTS LIST**
1. NUT
 2. WASHER
 3. SEAL CUP
 4. O-RING (SEAL)
 5. GRIPS
 6. O-RING (GRIPS)
 7. MANDREL

PIPE I.D. SIZES
1.278" – 2.067"

PIPE I.D. SIZES
2.900" – 11.938"

STOPPER SIZE	THAXTON PART #	NOMINAL PIPE SIZE	"A" DIM.	"B" DIM.	INSTALLATION TOOL SET PART NUMBER	NUT THREAD SIZE
1.278	RP-D-1.278-0	1-1/4" SCH. 80	3-1/2"	2.52"	IT-RP-1.25	5/8-18
1.337	RP-D-1.337-0	1-1/2" SCH. 160	3-1/2"	2.52"	IT-RP-1.5	5/8-18
1.500	RP-D-1.500-0	1-1/2" SCH. 80	3-5/8"	2.66"	IT-RP-1.5	5/8-18
1.610	RP-D-1.610-0	1-1/2" SCH. 40	3-5/8"	2.65"	IT-RP-1.5	5/8-18
1.939	RP-D-1.939-0	2" SCH. 80	3-7/8"	2.82"	IT-RP-2	7/8-14
2.067	RP-D-2.067-0	2" SCH. 40	3-7/8"	2.82"	IT-RP-2	7/8-14
2.900	RP-D-2.900-0	3" SCH. 80	5-7/8"	3.46"	IT-RP-3	1 1/4-12
3.068	RP-D-3.068-0	3" SCH. 40	5-7/8"	3.46"	IT-RP-3	1 1/4-12
3.826	RP-D-3.826-0	4" SCH. 80	6"	3.46"	IT-RP-4	1 1/2-12
4.026	RP-D-4.026-0	4" SCH. 40	6-3/16"	3.42"	IT-RP-4	1 1/2-12
4.813	RP-D-4.813-0	5" SCH. 80	6-1/4"	3.48"	IT-RP-4	1 1/2-12
5.761	RP-D-5.761-0	6" SCH. 80	6-7/16"	3.92"	IT-RP-4	1 1/2-12
6.065	RP-D-6.065-0	6" SCH. 40	6-7/16"	3.91"	IT-RP-4	1 1/2-12
7.981	RP-D-7.981-0	8" SCH. 40	6-1/2"	4.18"	IT-RP-4	1 1/2-12
10.020	RP-D-10.020-0	10" SCH. 40	6-1/2"	4.52"	IT-RP-4	1 1/2-12
11.938	RP-D-11.938-0	12" SCH. 40	7-1/2"	4.23"	IT-RP-12	2"-12

THAXTON PIPE STOPPERS ARE FACTORY TESTED UP TO 3,000 PSI, DEPENDING ON SIZE
SPECIAL SIZES AND HIGHER PRESSURES CAN BE SUPPLIED PER CUSTOMER REQUIREMENTS