

TYPE “D” PIPE STOPPER

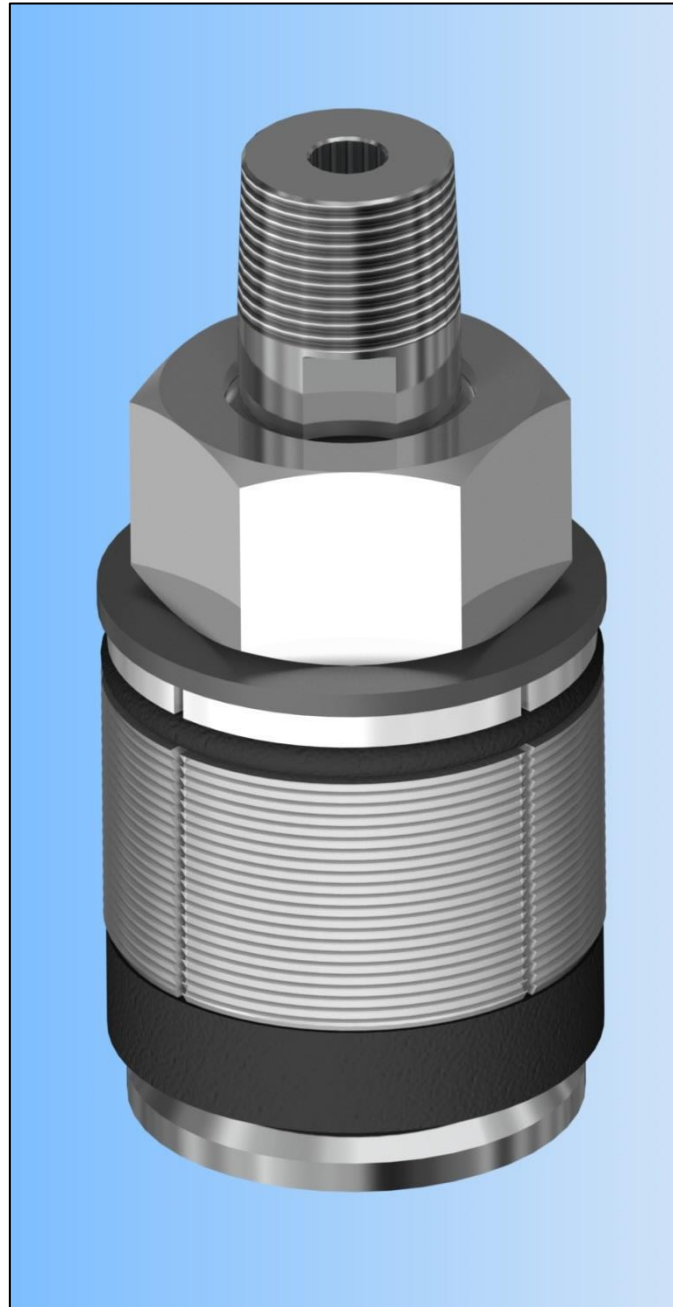

SIZES: 2-1/2” AND SMALLER

THAXTON

A DIVISION OF HY-TECH MACHINE, INC.

TYPE "D" PIPE STOPPER

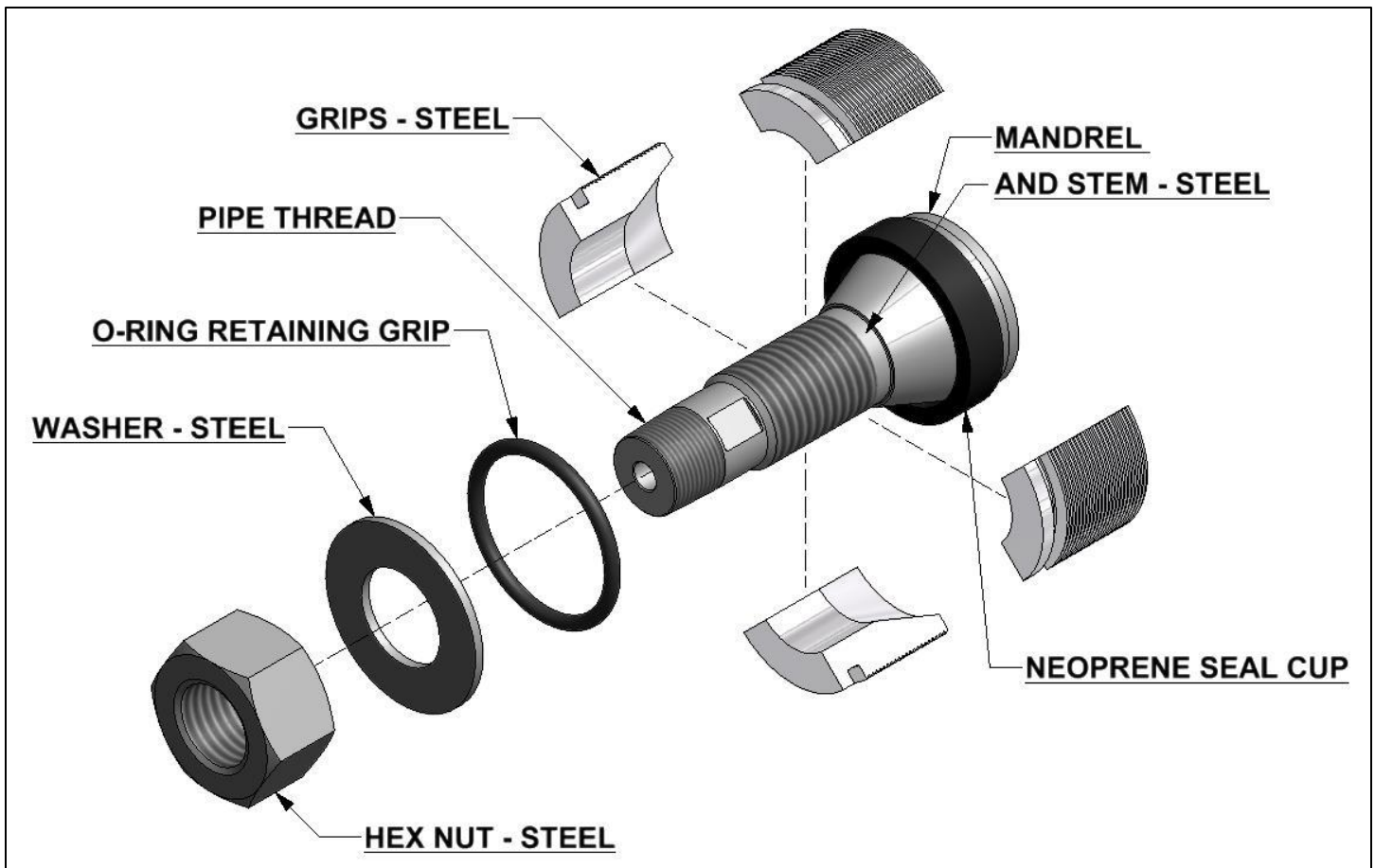

Standard Sizes: 1" Thru 2-1/2"

Most Schedule 40 and Schedule 80 sizes are available from stock.

Special Sizes:

- Made to fit specific inside diameters with tolerances of plus or minus 0.020"
- Available in sizes as small as 1" I.D.
- Hollow stem and pipe thread allows for filling or venting. (Solid stem optional)
- Steel parts are case hardened and plated.

Thaxton Standard Pipe Stoppers are factory tested up to 3,000 PSI, depending on size. Special sizes and higher pressures can be supplied per customer requirements. Thaxton stoppers are held in place by steel grips holding against the inside wall of the pipe when the nut is tightened... at the same time, a neoprene seal cup is compressed which ensures a tight seal. New neoprene seal cup and o-ring kit can be purchased directly from the factory. This prolongs the useful life of a Thaxton Pipe Stopper almost indefinitely. Visit our website at www.thaxtonplugs.com or call toll free (1-800-331-3827) for product and ordering information.



A DIVISION OF HY-TECH MACHINE, INC.

THAXTON TYPE “D” INSTALLATION INSTRUCTIONS

0.980” – 2.750” INSIDE DIAMETER

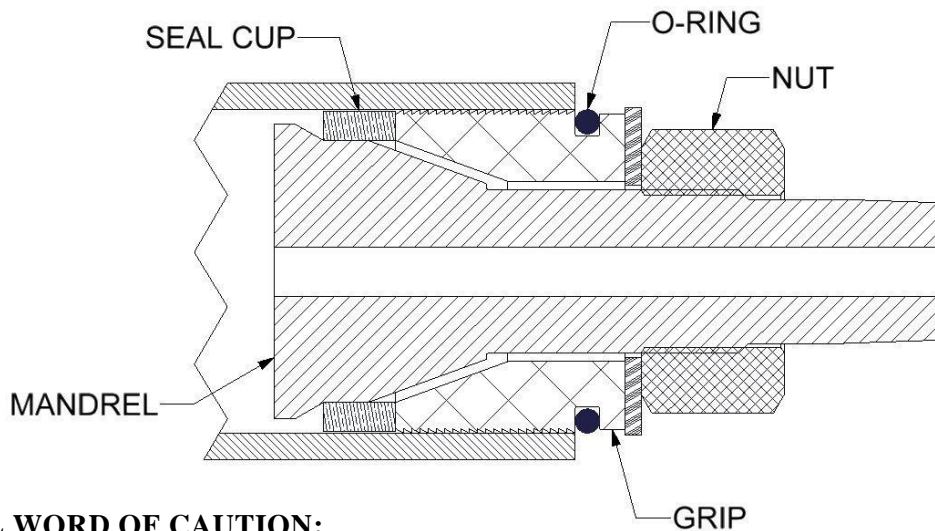

A SPECIAL WORD OF CAUTION:

THAXTON, DIVISION OF HY-TECH MACHINE, INC. ENGINEERS AND MANUFACTURES A SUPERIOR HIGH PRESSURE TEST PLUG. HOWEVER, PRESSURE TESTING CAN BE AN EXTREMELY HAZARDOUS OPERATION AND SAFETY PRECAUTIONS SHOULD BE STRICTLY ADHERED TO. ALL CONNECTIONS, VALVES, FLANGES AND OTHER FITTINGS SHOULD BE CHECKED FOR SUITABILITY TO TEST PRESSURE. IF AIR OR COMPRESSED GAS IS USED AS A TEST MEDIUM, A SAFETY GAG AND BARRIER SHOULD BE INSTALLED TO PREVENT ACCIDENTAL DISCHARGE OF PLUG. **-MOST IMPORTANTLY- NEVER STAND IN FRONT OF ANY TEST PLUG OR OTHER ENCLOSURE WHILE TEST IS IN PROGRESS. IF PLUG DISCHARGES DURING A TEST, SERIOUS INJURY OR DEATH COULD OCCUR.**

INSTALLATION:

- 1) REMOVE ANY ACCUMULATED DIRT, RUST PARTICLE, SCALE, ETC. FROM INSIDE OF PIPE END. SPECIAL CLEANING OF PIPE IS NOT NECESSARY.
- 2) REMOVE BURRS OR SHARP EDGES THAT COULD DAMAGE THE SEAL CUP OR INTERFERE WITH THE PROPER OPERATION OF THE STOPPER.
- 3) HOLDING STOPPER AT SLIGHT ANGLE, PLACE EDGE OF SEAL CUP ON LIP OF PIPE. INSERT PLUG EVENLY.
- 4) INSERT STOPPER SO THAT GRIPS ARE FLUSH WITH PIPE END.
- 5) TIGHTEN HEX NUT UNTIL GRIPS ARE FIRMLY SEATED AGAINST INSIDE WALL OF PIPE TUBING.
- 6) INSTALL SAFETY GAG. [SEE INSTRUCTIONS ON REVERSE]
- 7) FILL PIPE WITH WATER AND VENT ANY REMAINING AIR. THIS CAN BE ACCOMPLISHED BY ELEVATING THE VENT END SLIGHTLY. WATER SHOULD BE RUN IN A STEADY STREAM WITHOUT BUBBLING. **ALL AIR MUST BE VENTED BEFORE PRESSURIZATION!**
- 8) CLOSE ALL VALVES, PORTS, VENTS, ETC.
- 9) BEGIN TESTING BY SLOWLY INCREASING PRESSURE INTO PIPE.
- 10) BEING CAREFUL NOT TO STAND IN FRONT OF PLUG, **RETIGHTEN THE HEX NUT WHILE INCREASING PRESSURE.**

REMOVAL:

- 1) SHUT OFF THE PRESSURE SOURCE.
- 2) **SLOWLY** OPEN VALVE TO RELEASE STORED PRESSURE. RAPID RELEASE OF PRESSURE COULD CAUSE PLUG TO ACCIDENTLY DISCHARGE.
- 3) COMPLETELY DRAIN THE PIPE ASSEMBLY.
- 4) LOOSEN HEX NUT TWO OR THREE TURNS.
- 5) USING A RUBBER Mallet, TAP THE MANDREL FORWARD AND THE HEX NUT ON EACH SIDE. THIS WILL BREAK THE SEAL AND RELEASE ANY FRICTION.
- 6) SLIDE STOPPER OUT OF PIPE.
- 7) DRY AND CLEAN PIPE STOPPER BEFORE STORAGE.

SAFETY GAG INSTALLATION INSTRUCTIONS

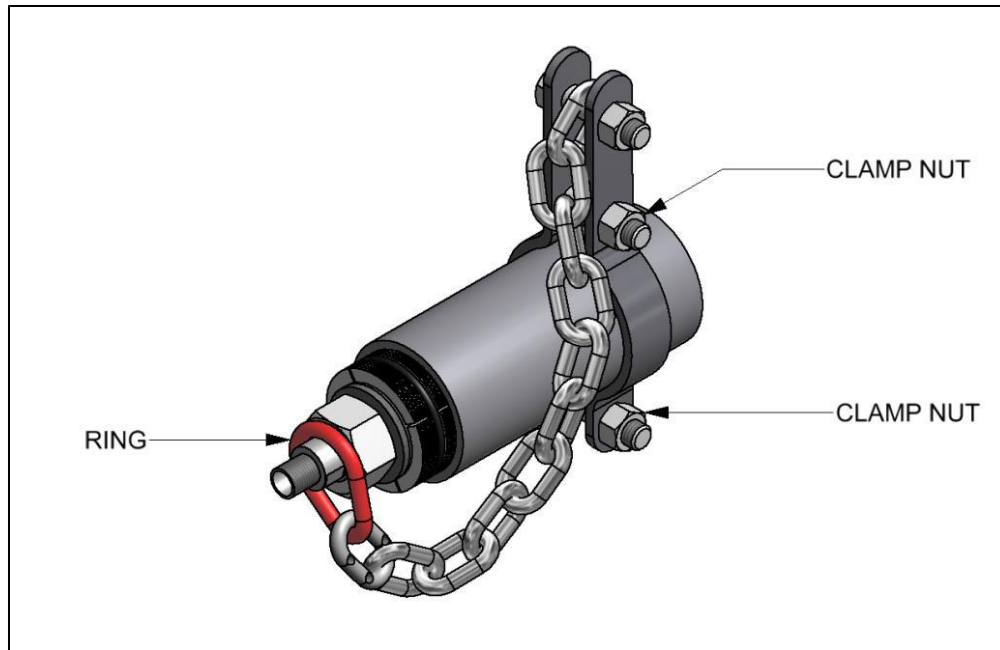

WHEN PROPERLY INSTALLED, ACCORDING TO OUR INSTRUCTIONS, THE **THAXTON PIPE STOPPER** IS A SAFE TOOL THAT WILL GIVE MANY YEARS OF SATISFACTORY SERVICE. HOWEVER, AS AN EXTRA SAFETY FACTOR, WE RECOMMEND USE OF A SAFTEY GAG. IT SHOULD BE INSTALLED AFTER THE PLUG IS IN PLACE AND BEFORE PRESSURE IS ADDED.

- 1) LOOSEN CLAMP NUTS ON SAFETY GAG AND SLIDE THE UNIT OVER THE END OF THE PIPE.
- 2) PLACE RING OVER THE END OF THE STOPPER, MAKING SURE THAT IT IS RESTING AGAINST THE STOPPER.
- 3) SLIDE CLAMP BACK UNTIL THE CHAIN IS SLIGHTLY TIGHT, LEAVING ROOM TO RETIGHTEN STOPPER HEX NUT.
- 4) TIGHTEN CLAMP NUTS SO THE SAFETY GAG WILL NOT MOVE.
- 5) PROCEED WITH PLUG INSTALLATION INSTRUCTIONS.

THAXTON

A DIVISION OF HY-TECH MACHINE, INC.

25 Leonberg Road
Cranberry Township, PA 16066
1-800-331-3827
FAX: (724) 776-6811
www.thaxtonplugs.com
Email: info@hy-techinc.com