

CONFIGURATIONS

MODEL #	1	3	21	22	24
ATP478HL-6	1A	3B	21A	22A	24A
ATP460HL-8	1A	3A	21B	22B	24B
ATP478HG-6	1B	3B	21A	22A	24A
ATP460HG-8	1B	3A	21B	22B	24B

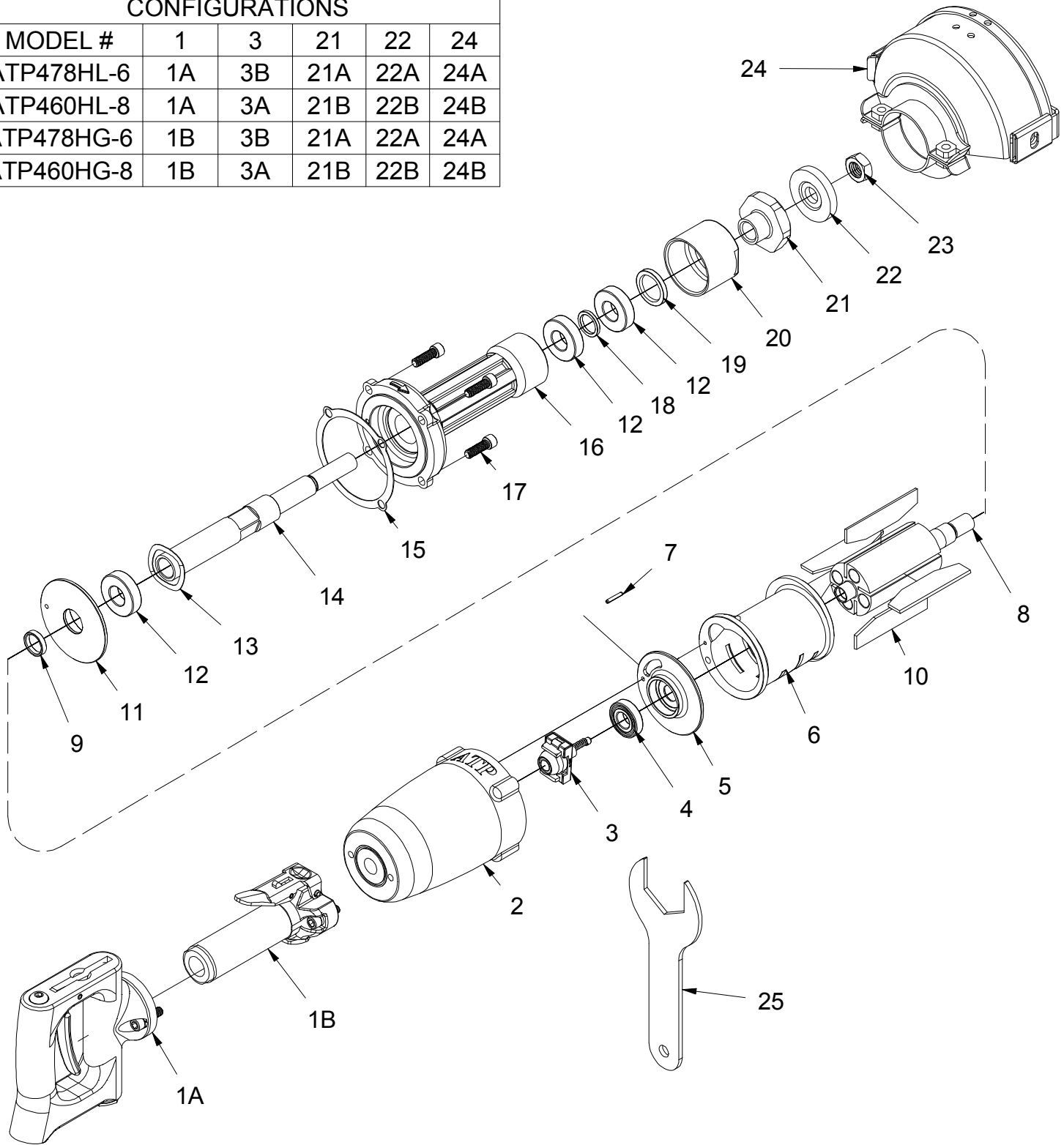

ATP

A DIVISION OF

HY-TECH

ENGINEERED SOLUTIONS

25 LEONBERG ROAD
CRANBERRY TOWNSHIP, PA 16066

4HP HORIZONTAL GRINDER PARTS LIST

ITEM	PART NUMBER	DESCRIPTION	QTY
1A	AA-550-H-3	SPADE HANDLE ASS'Y	1
1B	69A-E12	THROTTLE HANDLE ASSEMBLY	1
2	460HL-1-HC-M	4HP HORIZONTAL GRINDER MOTOR HOUSING	1
3A	AA-550-60	6000 RPM GOVERNOR ASSEMBLY	1
3B	AA-550-78	7800 RPM GOVERNOR ASSEMBLY	1
4	700-9	BALL BEARING	1
5	360-3	REAR END PLATE	1
6	460-2M	CYLINDER	1
7	2125-0750	PIN, SPRING, 1/8IN DIA X 3/4IN LG	2
8	460-5A	ROTOR ASSEMBLY	1
9	360-4	REAR SPACER	1
10	460-6	ROTOR BLADE	4
11	360-10	FRONT END PLATE	1
12	5459	R12ZZ BALL BEARING	3
13	560-20	WAVE SPRING WASHER	1
14	360HL-8H	HORIZONTAL GRINDER SPINDLE	1
15	360HL-13	HORIZONTAL GRINDER GASKET	1
16	360HL-1H-M	HORIZONTAL GRINDER SPINDLE HOUSING	1
17	700-48	5/16-18 X 1 CAP SCREW	4
18	7064-360HL-01	BEARING SPACER	1
19	650-H-14	SEAL	1
20	650-H-13	BEARING CAP	1
21A	700-5	6" STANDARD REAR FLANGE	1
21B	540620	8" STANDARD REAR FLANGE	1
22A	700-4	6" STANDARD FRONT FLANGE	1
22B	540619	8" STANDARD FRONT FLANGE	1
23	8615	5/8-11 JAM NUT	1
24A	650-HS-56A	6" GRINDER GUARD	1
24B	650-HS-58A	8" GRINDER GUARD	1
25	1100-200	2" END WRENCH	1

ATP

A DIVISION OF

HY-TECH
ENGINEERED SOLUTIONS

25 LEONBERG ROAD
CRANBERRY TOWNSHIP, PA 16066